

# KUBOTA DIESEL ENGINE SUPER MINI SERIES

E-TVCS

Two New Additions



Z602

D902

*Higher Density in a Smaller Body*

*Displacement Range: 479cc ~ 898cc*

*Output Range: 9.3 kW ~ 17.5 kW*

*12.5 HP ~ 23.5 HP*

# Introduction

## New Additions to A Long Time Favorite

Kubota's longstanding devotion to research and development is the reason why it is known around the world as a manufacturer of top quality diesel engines.

One of Kubota's major concerns has always been to develop more compact, fuel efficient, and cleaner exhaust engines.

With its outstanding technical experience, untiring research, and deep concern for the environment, Kubota developed the world's smallest, multi-cylinder high power density diesel engine series, the SUPER MINI in 1983. Starting out with just two models, this series remained a long time favorite for twenty years.

In 2003, two new models joined this ever-popular 2-, 3-cylinder series. The new lineup will undoubtedly keep the SUPER MINI series popular for years to come.

### New Model Features

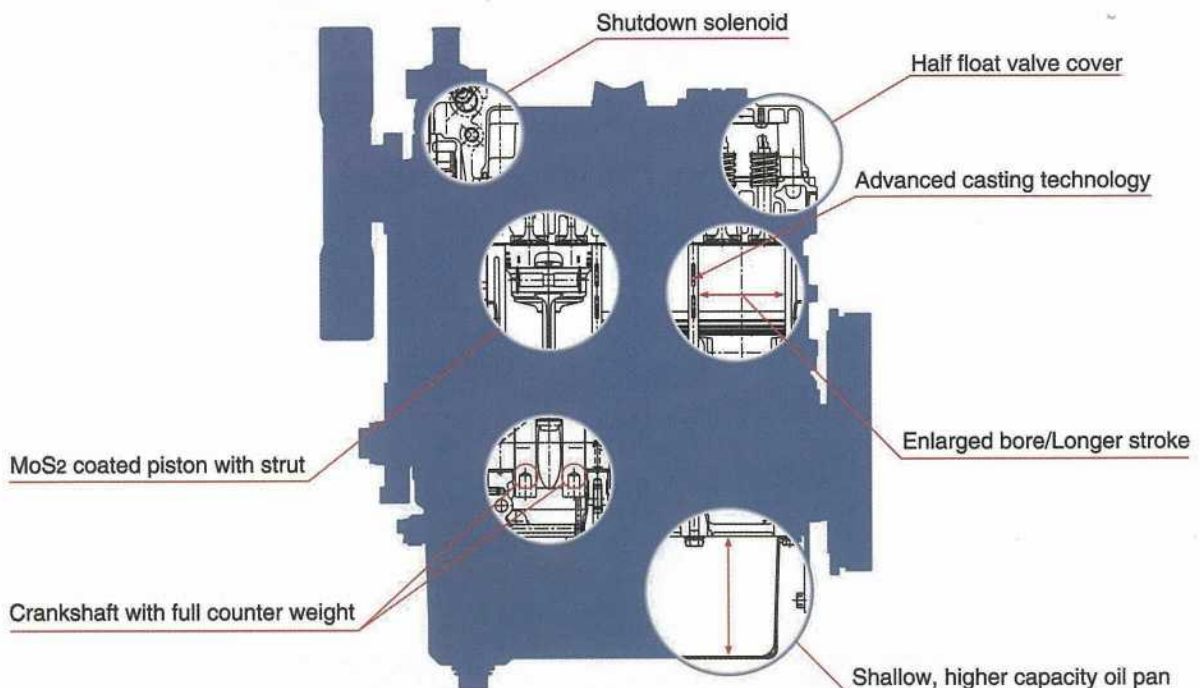

### E-TVCS

- Cleaner exhaust
- Capable of meeting future emission regulations

### Low Noise

- MoS2 Coated Piston (Z602/D902)
- Half Float Valve Cover (Z602/D902)

### Higher Power Density

- Larger Bore x Stroke:  $\varnothing 67 \rightarrow \varnothing 72$  (Z602/D902)
- Lower Engine Height (Z602/D902)

### Seamless Output Range



# E-TVCS

## Technology for the clean age.

Kubota's proprietary TVCS (Three Vortex Combustion System) obtains an optimum air/fuel mixture by generating three intense swirling air flows (vortexes) within the spherical-combustion (swirl) chamber.

The New TVCS added a special concave recess on the piston head to force compression air in the swirl chamber and to smooth combustion gas exhaust.

The E-TVCS, based on the New TVCS, is aimed at a drastic emission reduction.

### E-TVCS (IDI)

E-TVCS produces far less soot, HC and CO thanks to a better match between the injection nozzle throat and the concave recess on the piston head.

The injection pump and nozzle are better matched with the combustion chamber to reduce NOx emissions.



1. Throat of Combustion Chamber
2. Swirl Chamber
3. Three Vortex
4. Injection Nozzle
5. Swirl Chamber
6. Glow Plug
7. Concave Recess
8. Valve Recess
9. Piston

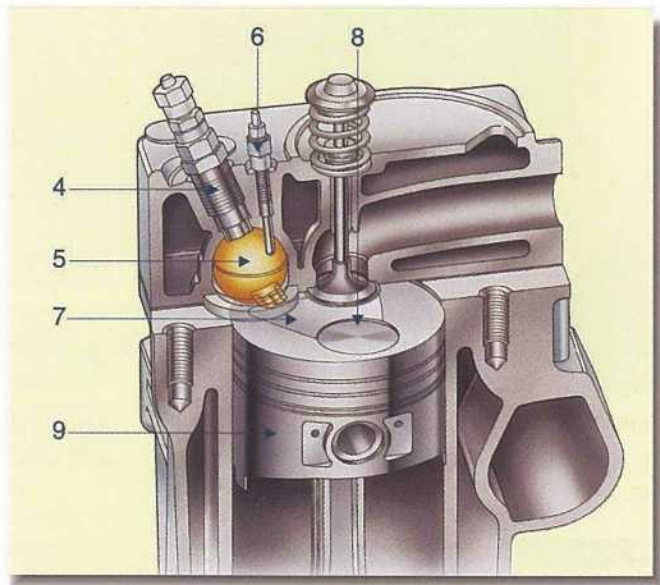

Meets all applicable emissions regulations world wide.

# High Power Density

## Smaller Yet More Powerful

The two new models' engine width is the same as the first two models; however, their larger bore and stroke sizes ( $\varnothing 67 \rightarrow \varnothing 72$ ) enable them to deliver more power. The newer models' compact oil pan and cylinder head decreased their engine height. With similar volume, the D902 displays a 16% increase in power density over the D905, while the Z602 displays an 18% increase over the Z482.

### Height comparison

The newly added D902 has the same output power as the D905 (15.1 kW (20.2HP/3200rpm), yet the D902 is 60.6 mm shorter in height and 30.7mm shorter in length than the D905.

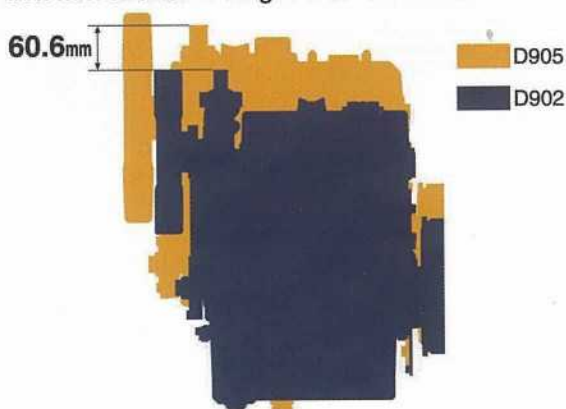

### Crankcase comparison

Even though the two share the same bore/stroke (72mm/73.6mm) size, the D902's crankcase is much smaller than the D905's.

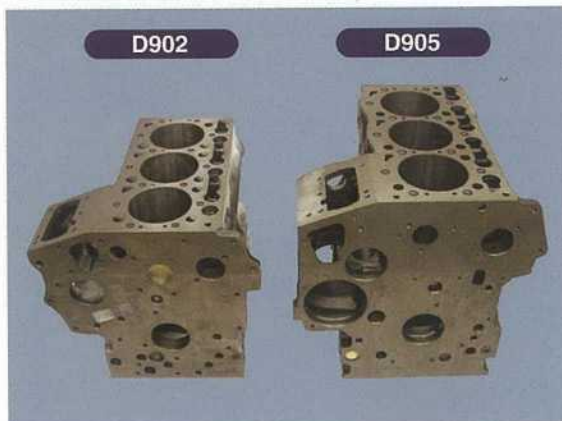

### Power density comparison

Comparison of the D902 and the Z602's power density with the D905 and other SUPER MINI engines.

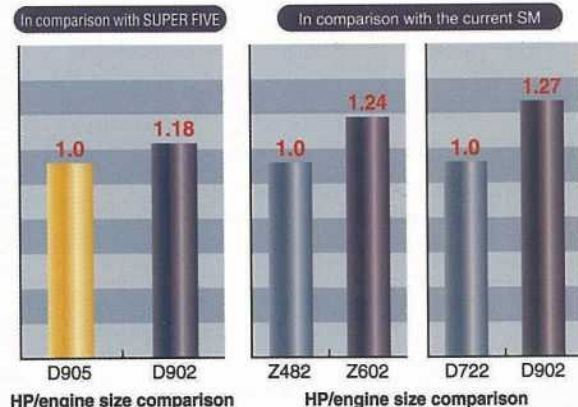

### Oil pan comparison

The oil pan in the D902 and the Z602 is longer and shallower to reduce engine size.

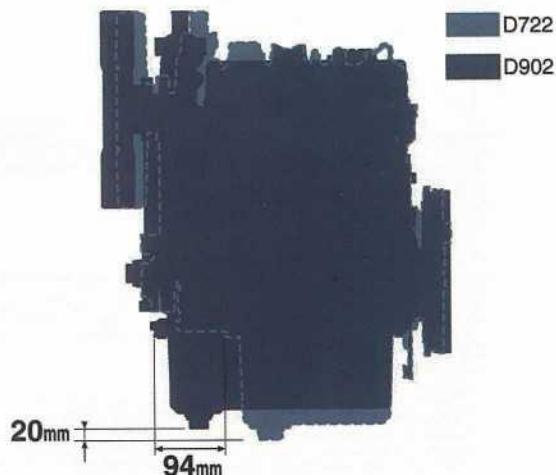



# Lower Noise

## More Comfort from Less Noise.

In order to improve the already well-established lower noise levels of the existing engines, Kubota added a half float head cover, and a MoS<sub>2</sub> coated piston to the Z602 and the D902.

### Half Float Valve Cover (for Z602/D902)

The rubber ring seals and isolates vibration, and reduces the noise from the crankcase. As a result, the noise level is 1.0~1.5 dBA lower than that of the conventional models in the same class.

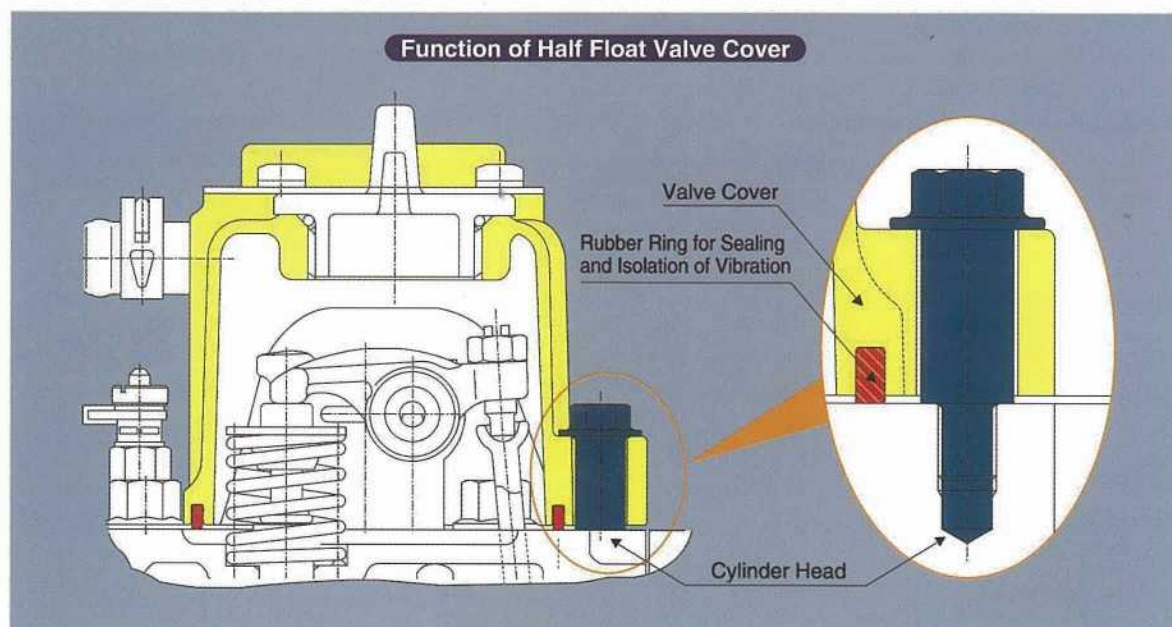

### MoS<sub>2</sub> Coated Piston (for Z602/D902)

Sulfured molybdenum coating enables clearance reduction between the piston and the cylinder liner, thus optimizing the oval shape ratio and decreasing the piston slapping noise.



# Other Features

... and Much More.

## Quick Start Ups

Super glow system comes as standard equipment to shorten preheating time and quicken engine start up in cold temperatures.

## Highly Reliable Engine

Based on Kubota's original sturdy design, the engine promises great reliability and long service life with advantages to meet most any application.

## Accessories / Options

A full range of accessories and options are available to meet customer's requirements.

● Radiator kit ● Air cleaner kit ● Muffler kit ● Fuel filter ● Key switch ● Mounting legs





# Specifications

## Full Lineup



Z482



Z602



D722



D902

Model			Z482	Z602	D722	D902	
Cylinders			2		3		
Bore x Stroke			67(2.64)x68(2.68)	72(2.83)x73.6(2.90)	67(2.64)x68(2.68)	72(2.83)x73.6(2.90)	
Displacement			0.479(29.23)	0.599(36.55)	0.719(43.88)	0.898(54.80)	
Combustion / Intake system			E-TVCS,NA				
Cooling system			Liquid-Cooled				
Starter			V-kW	12-0.7	12-1.0	12-0.7	12-1.2
Output	Gross Intermittent	3600rpm	kW/HP/PS	9.9/13.3/13.5	12.5/16.8/17.0	14.9/20.0/20.3	18.5/24.8/25.2
		3200rpm		—	10.8/14.5/14.7	—	16.1/21.6/21.9
		3000rpm		8.3/11.1/11.3	—	12.4/16.6/16.9	—
	Net intermittent	3600rpm	kW/HP/PS	9.3/12.5/12.7	11.6/15.5/15.8	14.0/18.8/19.1	17.5/23.5/23.8
		3200rpm		—	10.3/13.8/14.0	—	15.4/20.6/20.9
		3000rpm		7.9/10.6/10.8	—	11.9/15.9/16.1	—
	Net Continuous	3600rpm	kW/HP/PS	8.1/10.9/11.0	10.1/13.5/13.7	12.2/16.3/16.6	15.2/20.4/20.7
		3200rpm		—	8.8/11.8/12.0	—	13.4/17.7/18.2
		3000rpm		6.9/9.2/9.3	—	10.3/13.8/14.0	—
Dimensions	Length	mm(in.)	360.6(14.20)	384.6(15.14)	435.1(17.13)	467.1(18.40)	
	Width	mm(in.)	404.0(15.91)	404.0(15.91)	404.0(15.91)	404.0(15.91)	
	Height	mm(in.)	564.1(22.21)	544.1(21.42)	564.1(22.21)	544.1(21.42)	
Dry Weight			kg(lb)	53.1(117.1)	60.0(132.3)	63.1(139.1)	72.0(158.8)

\*Specifications are subject to change without notice.

\*Dry weight is according to Kubota's standard specification. When specification varies, the weight will vary accordingly.

## Seamless output range

The SUPER MINI series can now cover a wide displacement range (0.479L to 0.898L) and varied output range (9.3 kW to 17.5 kW). The newly introduced the Z602 and the D902 filled in the gap that existed between the SUPER MINI and the SUPER 05 series.

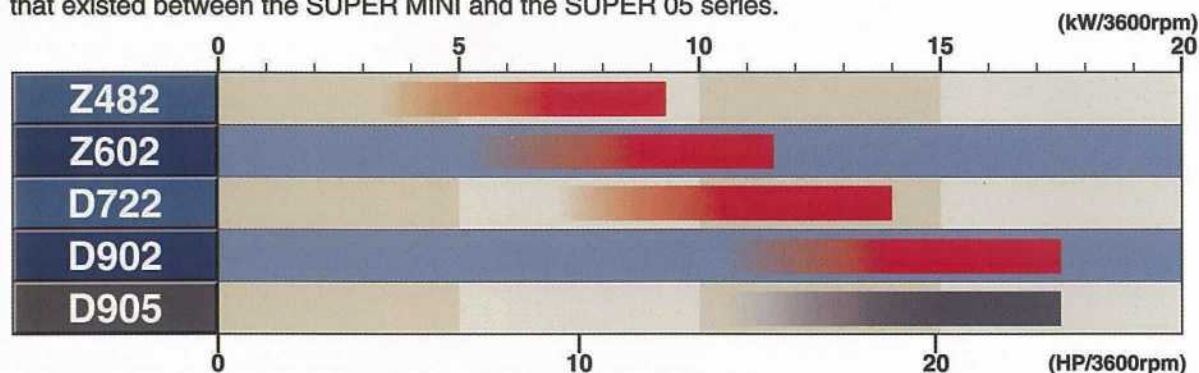

# Z482



## Dimensions mm(in.)

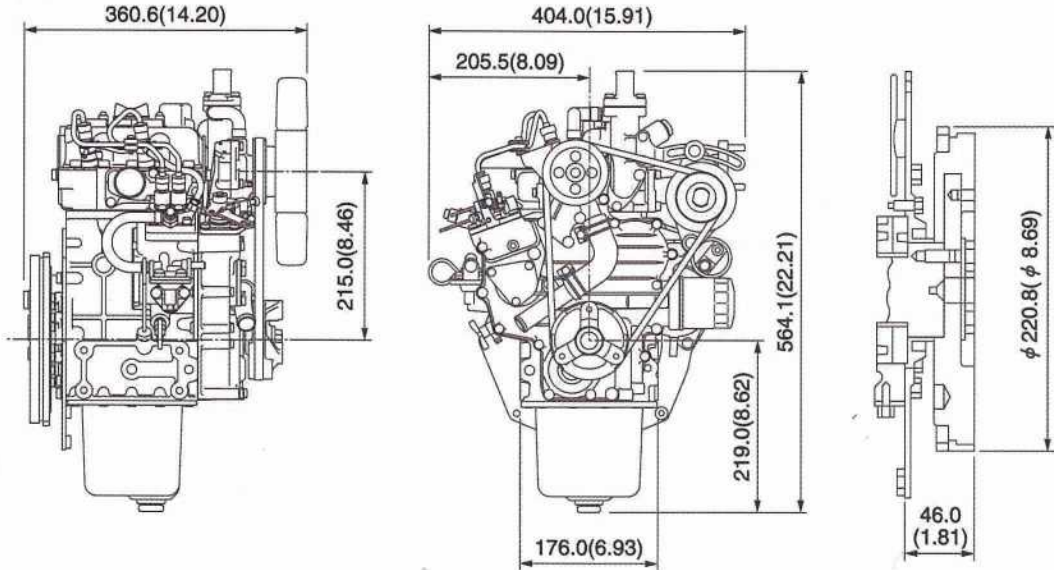

## Specifications

Model		Z482		
Cylinders		2		
Bore x Stroke		mm (in)	67 x 68 (2.64 x 2.68)	
Displacement		L (cu.in.)	0.479 (29.23)	
Combustion / Intake system		E-TVCS,NA		
Cooling System		Liquid-Cooled		
Starter		V-A	12-0.7	
Output Industrial Use	Gross Intermittent	kW/HP/PS	3600	9.9/13.3/13.5
			3000	8.3/11.1/11.3
			2800	7.7/10.3/10.5
			2600	7.1/9.5/9.7
			2400	6.6/8.8/8.9
			2200	6.0/8.0/8.2
	Net Intermittent	kW/HP/PS	3600	9.3/12.5/12.7
			3000	7.9/10.6/10.8
			2800	7.4/9.9/10.0
			2600	6.9/9.2/9.3
			2400	6.3/8.4/8.6
			2200	5.8/7.8/7.9
Net Continuous	kW/HP/PS	3600	8.1/10.9/11.0	
		3000	6.9/9.2/9.3	
		2800	6.4/8.6/8.7	
		2600	6.0/8.0/8.1	
		2400	5.5/7.4/7.5	
		2200	5.1/6.8/6.9	
Output Generator Use	Stand-by	kW/HP/PS	3600	8.9/11.9/12.1
			3000	7.5/10.1/10.2
	Continuous	kW/HP/PS	3600	8.1/10.9/11.0
			3000	6.8/9.1/9.3
Dimensions	Length	mm(in.)	360.6(14.20)	
	Width	mm(in.)	404.0(15.91)	
	Height	mm(in.)	564.1(22.21)	
Dry Weight		kg (lbs)	53.1 (117.1)	

## Performance Curve

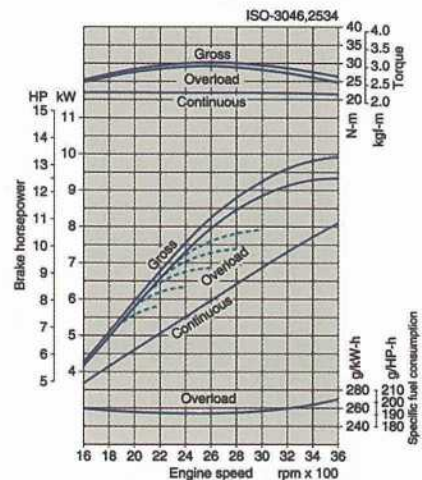
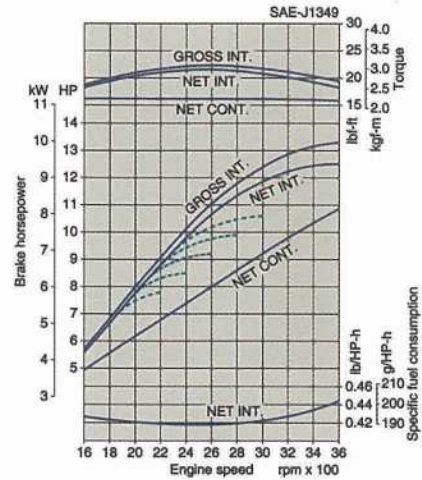

\*Specifications are subject to change without notice.  
 \*Dry weight is according to Kubota's standard specification.  
 When specification varies, the weight will vary accordingly.



# Z602



## Dimensions mm(in.)

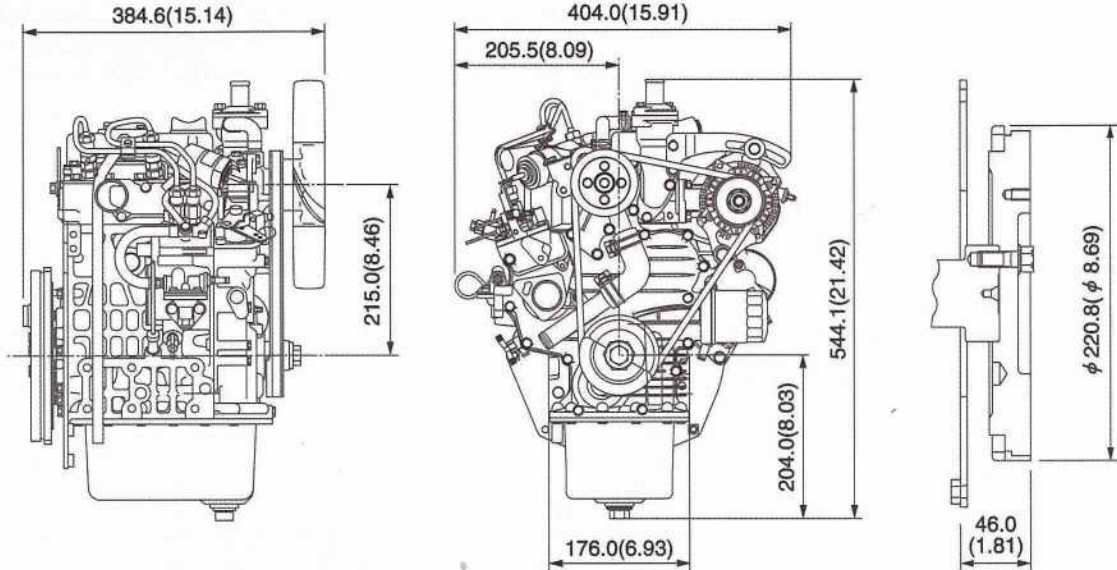

## Specifications

Model		Z602	
Cylinders		2	
Bore x Stroke		mm(in.)	72(2.83)x73.6(2.90)
Displacement		L(cu.in.)	0.599(36.55)
Combustion / Intake system		E-TVCS,NA	
Cooling system		Liquid-Cooled	
Starter		V-kW	12-1.0
Output	Gross Intermittent	3600rpm	kW/HP/PS 12.5/16.8/17.0
		3200rpm	10.8/14.5/14.7
	Net intermittent	3600rpm	kW/HP/PS 11.6/15.5/15.8
		3200rpm	10.3/13.8/14.0
	Net Continuous	3600rpm	kW/HP/PS 10.1/13.5/13.7
		3200rpm	8.8/11.8/12.0
Dimensions	Length	mm(in.)	384.6(15.14)
	Width	mm(in.)	404.0(15.91)
	Height	mm(in.)	544.1(21.42)
Dry Weight		kg(lb)	60.0(132.3)

\*Specifications are subject to change without notice.  
 \*Dry weight is according to Kubota's standard specification.  
 When specification varies, the weight will vary accordingly.

## Performance Curve

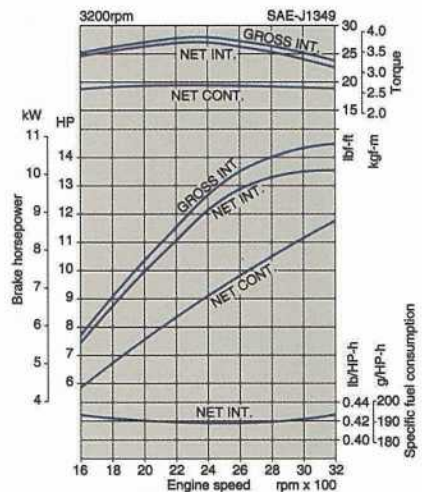
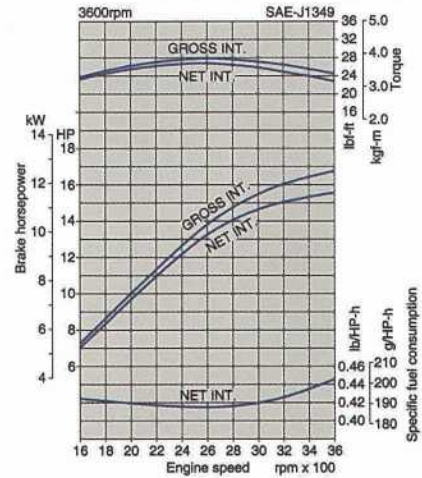

# D722



## Dimensions mm(in.)

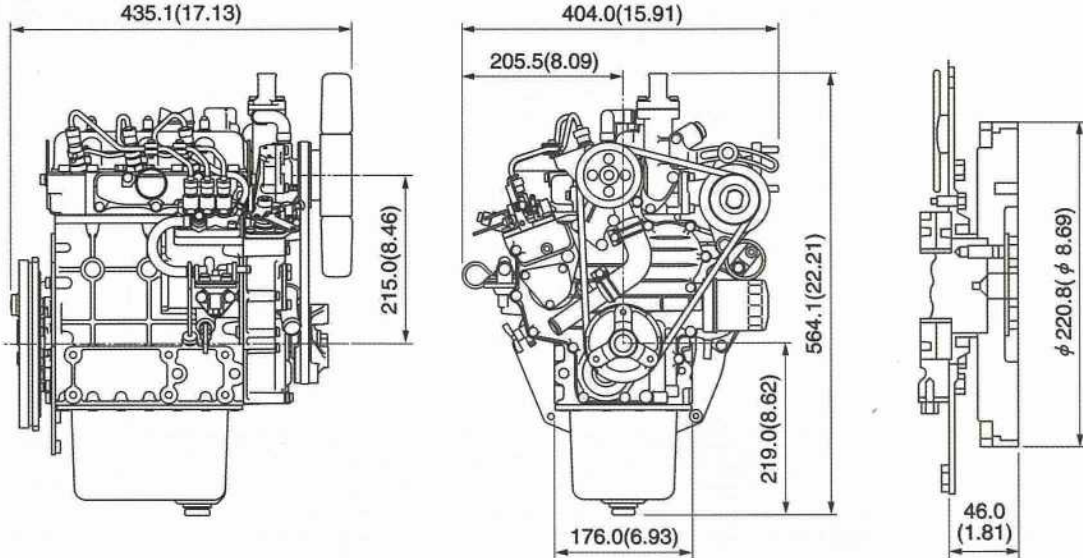

## Specifications

Model		D722	
Cylinders		3	
Bore x Stroke		mm (in)	67 x 68 (2.64 x 2.68)
Displacement		L (cu.in.)	0.719 (43.88)
Combustion / Intake system		E-TVCS, NA	
Cooling System		Liquid-Cooled	
Starter		V-A	12-0.7
Output Industrial Use	Gross Intermittent	3600	14.9/20.0/20.3
		3000	12.4/16.6/16.9
		2800	11.5/15.4/15.7
		2600	10.7/14.3/14.6
		2400	9.9/13.3/13.5
		2200	9.0/12.1/12.3
	Net Intermittent	3600	14.0/18.8/19.1
		3000	11.9/15.9/16.1
		2800	11.0/14.7/15.0
		2600	10.3/13.8/14.0
		2400	9.5/12.7/13.0
		2200	8.7/11.7/11.9
Net Continuous	3600	12.2/16.3/16.6	
	3000	10.3/13.8/14.0	
	2800	9.6/12.9/13.0	
	2600	8.9/11.9/12.2	
	2400	8.3/11.1/11.3	
	2200	7.6/10.2/10.3	
Output Generator Use	Stand-by	3600	13.4/18.0/18.2
		3000	11.3/15.1/15.4
	Continuous	3600	12.1/16.2/16.5
		3000	10.3/13.8/14.0
Dimensions	Length	mm(in.)	435.1(17.13)
	Width	mm(in.)	404.0(15.91)
	Height	mm(in.)	564.1(22.21)
Dry Weight		kg (lbs)	63.1(139.1)

## Performance Curve

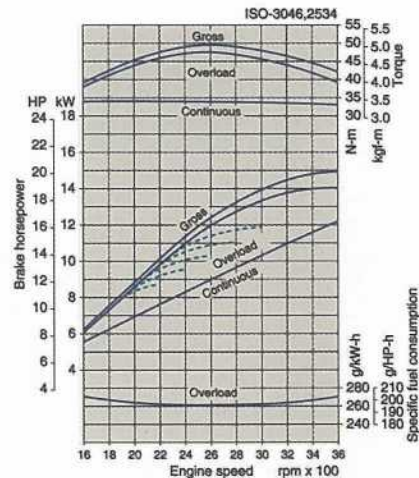
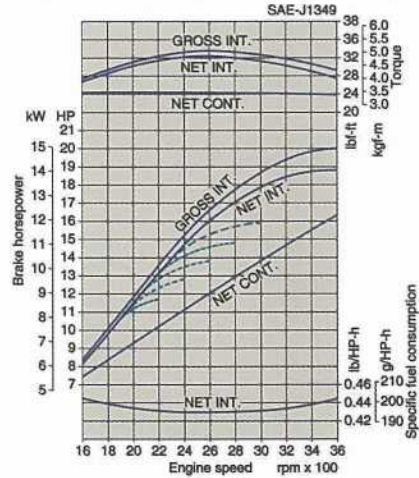

\*Specifications are subject to change without notice.  
 \*Dry weight is according to Kubota's standard specification.  
 When specification varies, the weight will vary accordingly.



# D902



## Dimensions mm(in.)

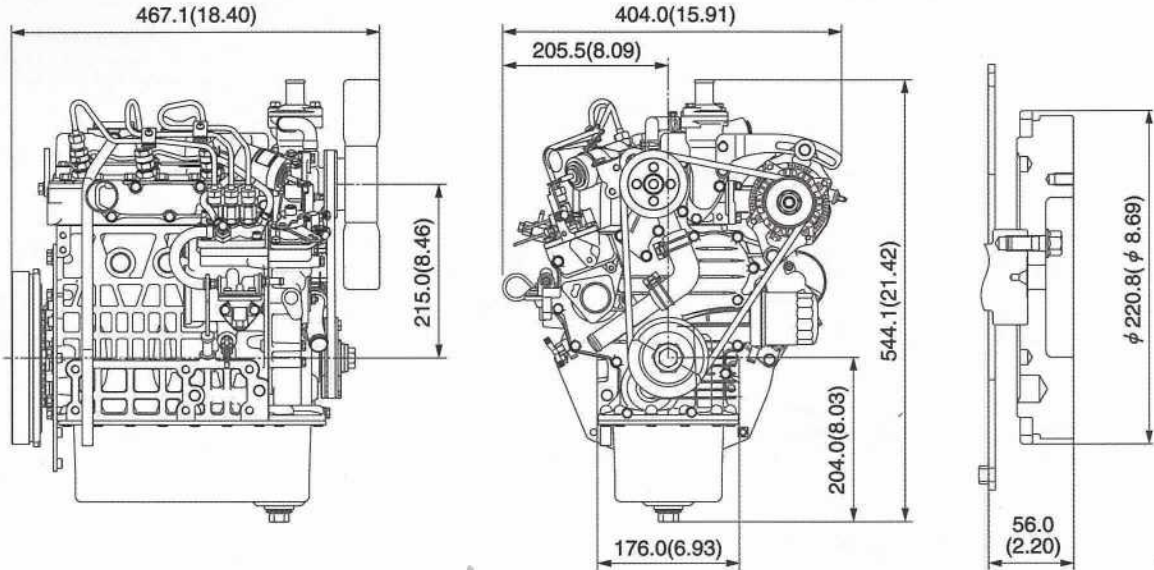

## Specifications

Model		D902	
Cylinders		3	
Bore x Stroke		mm(in.)	72(2.83)x73.6(2.90)
Displacement		L(cu.in.)	0.898(54.80)
Combustion / Intake system		E-TVCS,NA	
Cooling system		Liquid-Cooled	
Starter		V-kW	12-1.2
Output	Gross Intermittent	3600rpm	kW/HP/PS 18.5/24.8/25.2
		3200rpm	16.1/21.6/21.9
	Net intermittent	3600rpm	kW/HP/PS 17.5/23.5/23.8
		3200rpm	15.4/20.6/20.9
	Net Continuous	3600rpm	kW/HP/PS 15.2/20.4/20.7
		3200rpm	13.4/17.7/18.2
Dimensions	Length	mm(in.)	467.1(18.40)
	Width	mm(in.)	404.0(15.91)
	Height	mm(in.)	544.1(21.42)
Dry Weight		kg(lb)	72.0(158.8)

\*Specifications are subject to change without notice.  
 \*Dry weight is according to Kubota's standard specification.  
 When specification varies, the weight will vary accordingly.

## Performance Curve

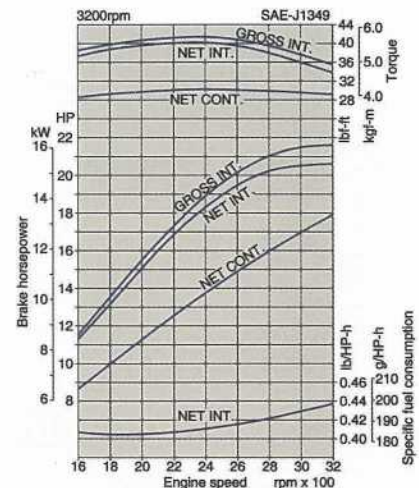
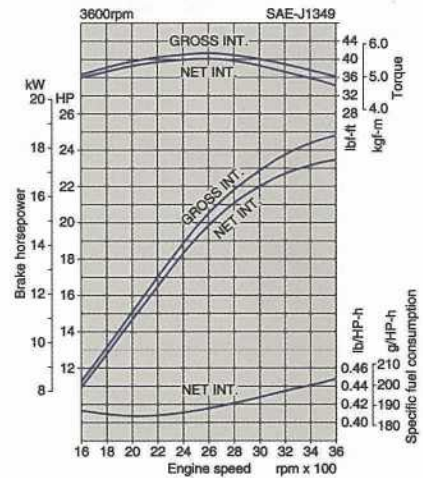

# Your Driving Force

---

## KUBOTA ENGINE

### Distribuidor Autorizado

Calle Uno - Mza. "A" - Lote 11 - Urb. Santo Tomas de Garagay

Lima 31 - Perú

Teléfonos: (511) 535-7393 / (511) 556-2512

Celular: (51) 9835-15428

Nextel: 41\*351\*5428

E-mail: [lacasadelbobcat@bobcatsservice.com](mailto:lacasadelbobcat@bobcatsservice.com)

Web.: [www.kubotadieselmotors.com](http://www.kubotadieselmotors.com)



### BobCat's Service & Parts S.A.C.

Maquinaria - Repuestos - Servicio Técnico Especializado - Alquileres

\*Specifications and dimensions are subject to change without prior notice.

### KUBOTA Corporation

2-47, Shikitsuhigashi 1-chome, Naniwa-ku, Osaka, 556-8601 Japan

Fax: 06-6648-3521 Telex: 5267785 KUBOTA J

<http://www.engine.kubota.ne.jp>

### Kubota Engine America Corporation

505 Schelter Road, Lincolnshire, IL 60069

Phone: 847-955-2500 Fax: 847-955-2699

<http://www.kubotaengine.com>

### Kubota Canada Ltd.

Engine Division:

5900 14th Avenue, Markham, Ontario L3S 4K4, Canada

Phone: 905-294-7477 Fax: 905-294-6651

<http://www.kubota.ca>

### Kubota (U.K.) Ltd.

Dorner Road, Thame Oxfordshire, OX9 3UN United Kingdom

Phone: 01844-214-500 Fax: 01844-216-685

<http://www.kubota.co.uk>

### Kubota EUROPE S.A.

Engine Division:

19-25 rue Jules Verducysse Z.I., BP 88, 95101 Argenteuil Cedex France

Phone: 33-1-3426-3419 Fax: 33-1-3426-3499

<http://www.kubota-europe.com>

### Kubota (Deutschland) GmbH

Engine Division:

Senefelder Str., 3-5, 63110 Rodgau/Nieder-Roden, Germany

Phone: (0) 6106-873-0 Fax: (0) 6106-873-199

<http://www.kubota.de>

### Kubota Tractor Australia Pty Ltd

100 Keilor Park Drive, Tullamarine Vic. 3043

Freecall: 1800 334 653 Email: [sales@kubota.com.au](mailto:sales@kubota.com.au)

<http://www.kubota.com.au>